

USER MANUAL

FOR LITHIUM RACK BATTERY ENERGY STORAGE SYSTEM

VERSION 1.0



APPLIED FOR
24V100Ah/150Ah/200Ah
48V100Ah/150Ah/200Ah
51.2V100Ah/150Ah/200Ah

Contents

| | |
|--|----|
| 1. Introduction | 3 |
| 2. Important Safety Warning | 3 |
| 2.1 Before Connecting | |
| 2.2 Necessary installation Tools..... | 4 |
| 2.3 Personal protective equipment..... | 5 |
| 2.4 During operation..... | |
| 3. Unpacking & Overview | 5 |
| 3.1 Packing List | 5 |
| 3.2 Product Overview | 5 |
| 4. Installation | 6 |
| 4.1 Selecting Mounting Location..... | 6 |
| 4.2 Mounting The PACK | 6 |
| 4.3 Battery Pack parameters:..... | 12 |
| Appendix 1..... | 14 |
| Appendix 2..... | |
| Product Responsibilities and Consulting..... | 18 |

Note: Please comply with all warnings and operating instructions in this manual strictly. Save this manual properly and read carefully the following instructions before installing the unit. Do not operate this unit before reading through all safety information and operating instructions carefully

1. Introduction

The Energy storage pack is an essential component of the photovoltaic power generation system. It can provide electricity for the connected load, and it can also store photovoltaic solar modules, fuel generators, or wind energy generators by charging the remaining energy in case of emergency. When the sun goes down, energy demand is high, or there is a power outage, you can use the energy stored in the system to meet your energy needs at no additional cost. In addition, the energy storage pack can help you achieve energy self-consumption and ultimately achieve the goal of energy independence.

According to different power conditions, the energy storage pack can output power during peak power consumption, and can also store energy during low power consumption. Therefore, when connecting the matching photovoltaic modules or inverter arrays, external equipment is required to match the energy storage the working parameters of the pack to achieve the highest operating efficiency. For a simple diagram of a typical energy storage system.

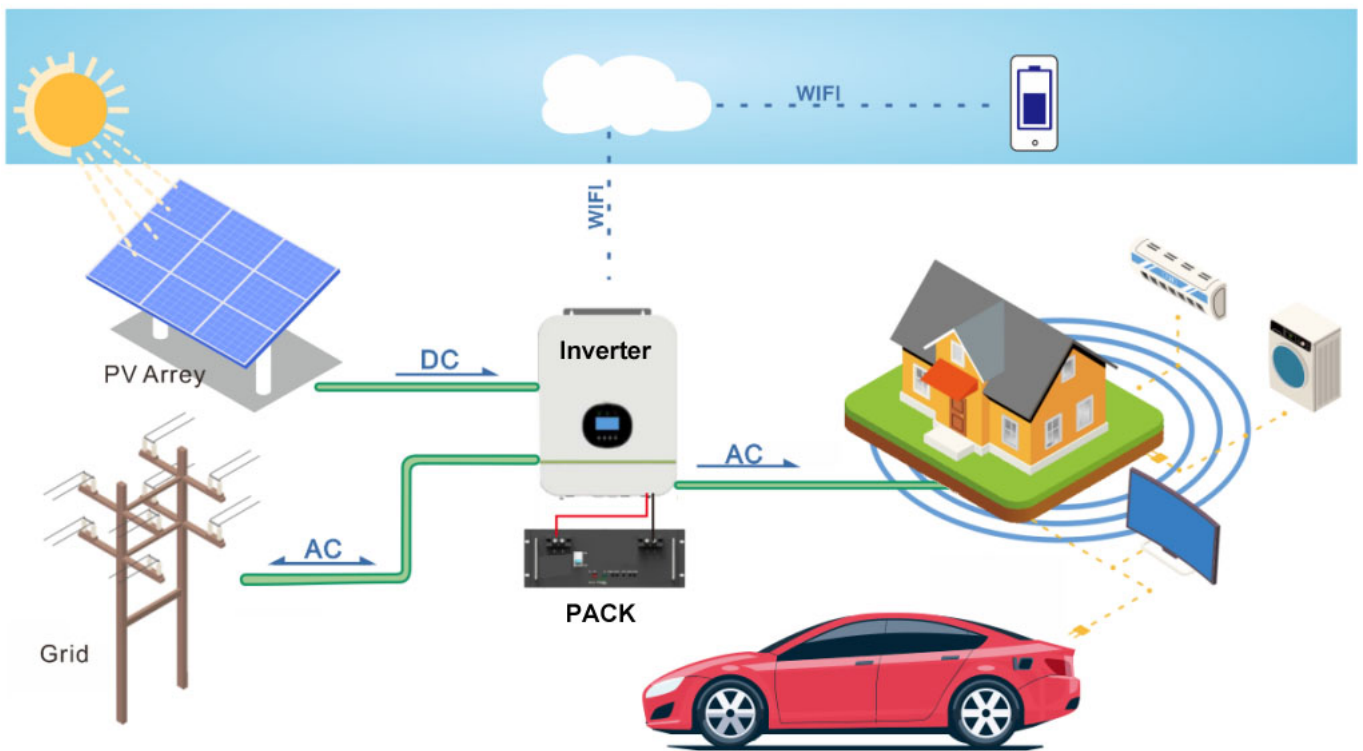

Figure1 . Energy storage System Overview

It is very important and necessary to read the user manual carefully before installing or using the battery. Failure to follow any of the instructions or warnings in this document can result in electrical shock, serious injury, death or may damage the battery and the whole system.



2. Important Safety Warning









- Do not expose the battery to flammable or harsh chemicals or vapors.
- Do not expose cable outside: Do not use cleaning solvents to clean the battery.
All battery terminals must be disconnected before maintenance.

- Do not paint any part of the battery, include any internal or external components.
- Do not connect battery with PV solar wiring directly.
- Any external object is prohibited to be inserted into any part of the battery.
- Our company will not bear any warranty claims for direct or indirect damage caused by violation of the above items.
- Our company will not bear any warranty claims for direct or indirect damage caused by violation of the above items.

Before Connecting

- After unpacking, please check the battery and pack list first, if the battery is damaged or spare parts are missing, please contact the dealer.
- Before installation, be sure to cut off the grid power and make sure the battery is in the turned-off mode;
- Wiring must be correct, do not mix-connect the positive and negative cables, and ensure no short circuit with the external device;
- It is prohibited to connect the battery with AC power directly;
- The BMS in the battery is designed for 24VDC/48VDC, DO NOT connect battery in series;
- It is prohibited to connect the battery with different type of battery;
- Please ensure the electrical parameters of battery system are compatible to inverter;
- Keep the battery away from fire or water.

2.1 Necessary installation tools.

| | | | |
|---|--|--|--|
|  <p>Multimeter + Current clamp</p> |  <p>Screw Driver Set</p> |  <p>Allen Key Set</p> |  <p>Drill + Hammer</p> |
|  <p>Electrician Scissors</p> |  <p>Wrench set</p> |  <p>Lifting strap + mechanical lifter</p> |  <p>RS 232/USB+screw terminal (insulated)</p> |





2.2 Personal protective equipment during operation:

- If the battery system needs to be moved or repaired, the power must be cut off first and the battery is completely shut down;
- It is prohibited to connect the battery with different type of battery;
- It is prohibited to put the batteries working with faulty or incompatible inverter;
- In case of fire, only dry powder fire extinguisher can be used, liquid fire extinguishers are prohibited;
- Please do not open, repair or disassemble the battery. We do not undertake any consequences or related responsibility due to violation of safety operation or violating of design, production and equipment safety standards.

3. Unpacking & Overview

3.1 Packing List

You will receive the following parts (Not a full set), sample as follow picture. For customized requirements, please place an order with the manufacturer.

| Battery pack | Cable | Manual |
|--|--|--|
|  |  |  |

*NOTE : Types of communication tools need extra order.

3.2 Product Overview

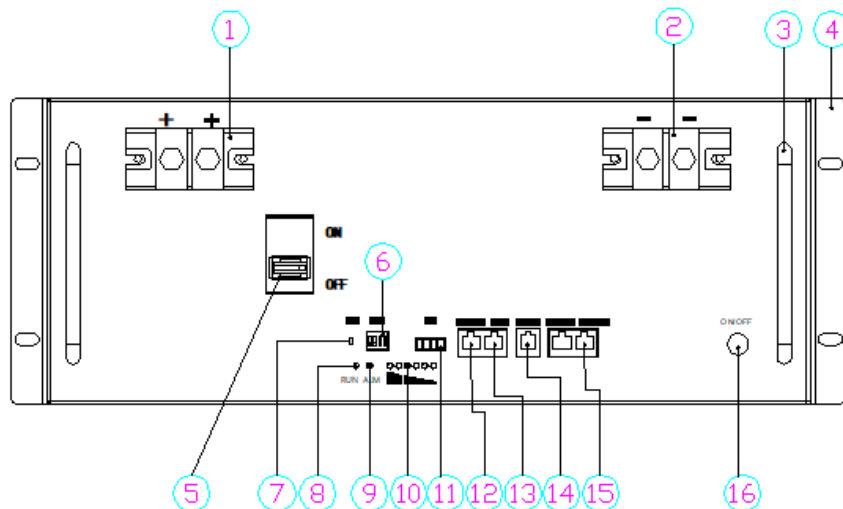

Figure 2 A General battery shape. Front view

| No. | Description | Silk-screen | Remark |
|-----|-----------------|-------------|--------------------------------------|
| 1 | Output terminal | + + | Output terminal |
| 2 | Output terminal | - - | Output terminal |
| 3 | Handle | | |
| 4 | bracket | | |
| 5 | Power Switch | ON OFF | |
| 6 | Dial switch | ADS | Set the address |
| 7 | Reset button | RST | For reset the batter |
| 8 | LED indicate | RUN | Operation indicator |
| 9 | LED indicate | ALM | Alarm indicator |
| 10 | LED indicate | CAPACITY | Capacity indicator |
| 11 | Dry port | DO | |
| 12 | RS485A Port | RS485A | RS485A and inverter connection port |
| 13 | CAN bus Port | CAN | CAN bus and inverter connection port |
| 14 | RS232 Port | RS232 | RS232 and computer connection port |
| 15 | RS485B Port | RS485B | battery and battery connection port |
| 16 | E-switch | ON/OFF | |

4. Installation

4.1 Selecting Mounting Location

Consider the following points to install the energy storage Pack:

- Do not mount the Pack on flammable construction materials. Mount on a solid surface;
- Install this Pack module at eye level in order to allow the readability of LCD display at all times.
- For proper air circulation to dissipate heat, please leave a gap of about > 0.3 meter from the ground, 30 cm from the side of the device.
- The ambient temperature should be between 0°C and 40°C and relative humidity should be between 25% and 85% to ensure optimal operation.
- The recommended installation is flat wise adherence.
- Install the battery module in a dry, protected area with no excessive dust and sufficient air circulation. Do not operate in locations where the temperature and humidity are outside the specified range.

4.2 Mounting The PACK (only for Parallel mode)



WARNING!! Remember that this Pack is heavy so please be careful when removing it from the package, or install it .

When installing the Pack bracket, use appropriate screws to fix it. After that, the equipment should be firmly bolted. The pack can be run indoors or outdoors. However, only professional personnel can enter this area for installation or maintenance.

Step 1: When receiving the product, first check whether all parts are complete, if not, please report to the dealer.

Step 2: Ensure that the Pack is installed on the Rack. Choose a suitable installation location and require the battery pack to be placed at a safe.

The first load-bearing plate should be at least 15cm away from the ground. The distance between the load-bearing plates is about 205mm. We recommend that the installation distance be 205mm.

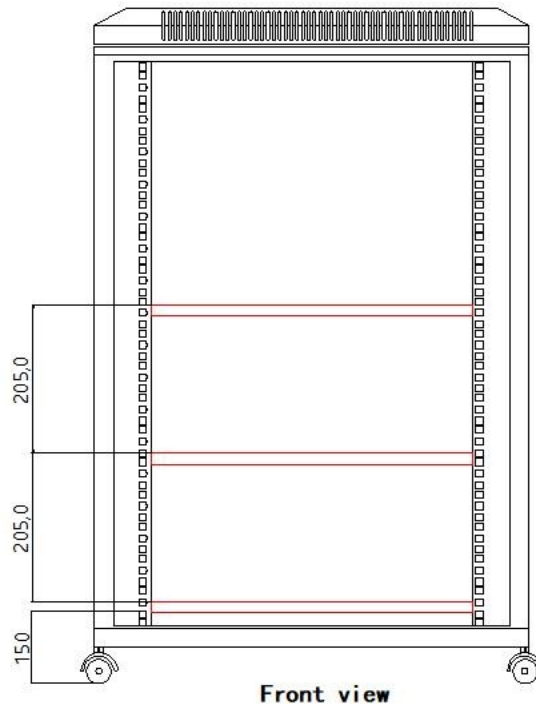

Figure3.

Step 3: Mark the position of the nut on the cabinet with the mounting bracket, and clamp the nut into the cabinet. See Figure4.

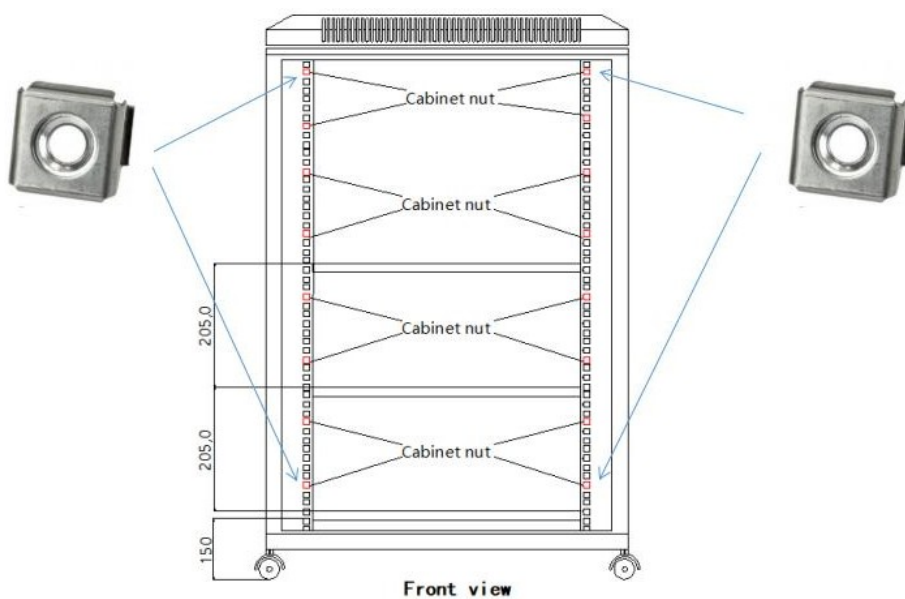

Figure 4

Step 4: As shown in the below, install the battery pack. The pack is too heavy, please use a special lifting device to lift the pack for operation and safety protection. Put the battery module into the cabinet and screw it, as shown in Figure 5.

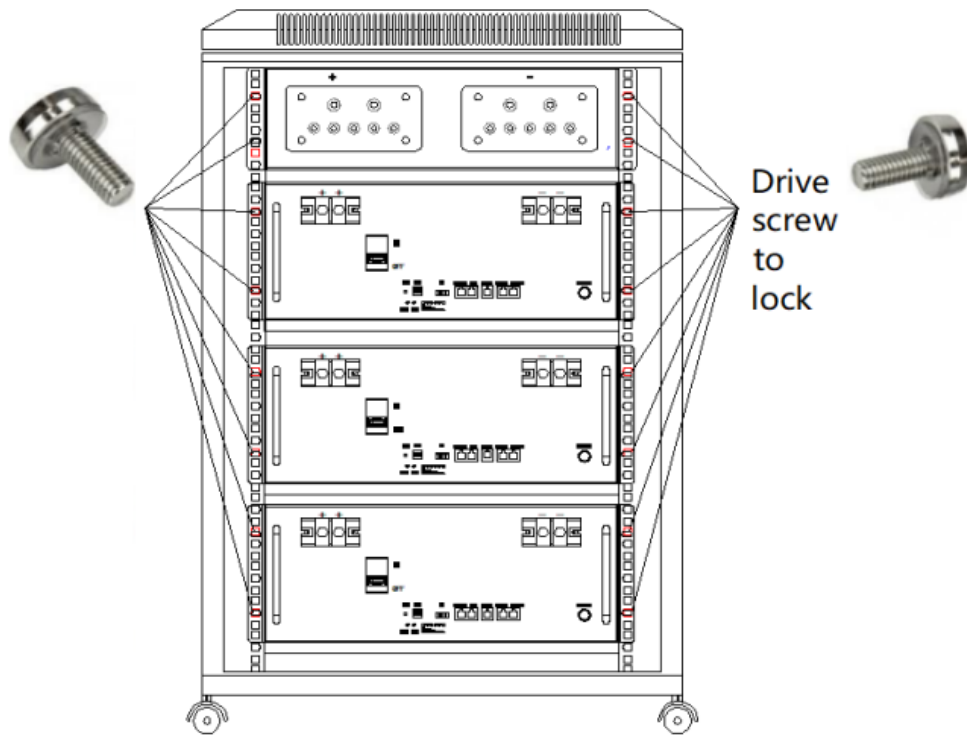

Figure 5.

Step 5: When more than 3 PCS packs are connected in parallel, then we recommend you install combiner box. 4 locations we recommend you install the combiner box. First select location is Top and Bottom ,see Figure6.

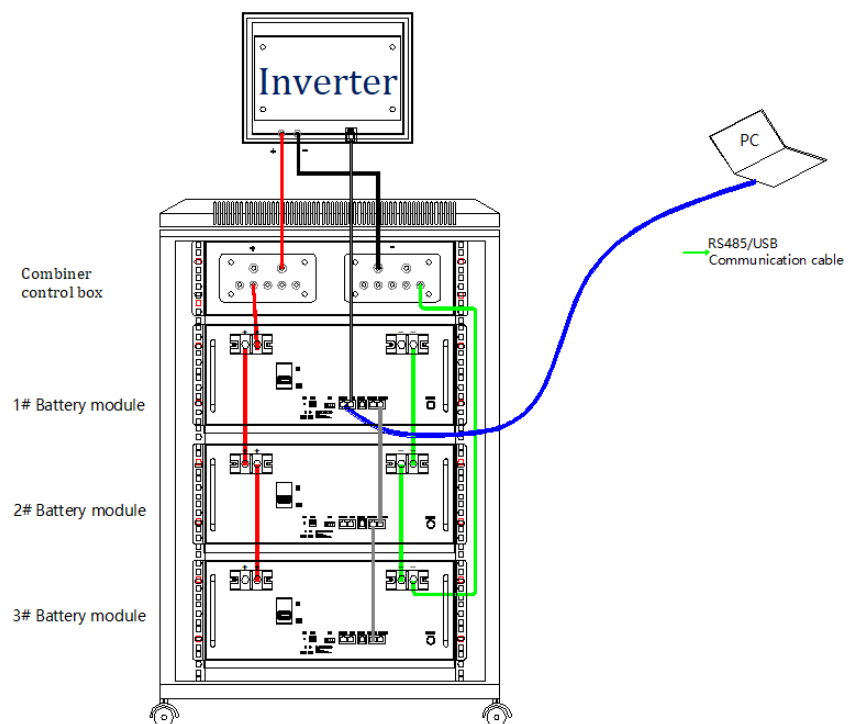
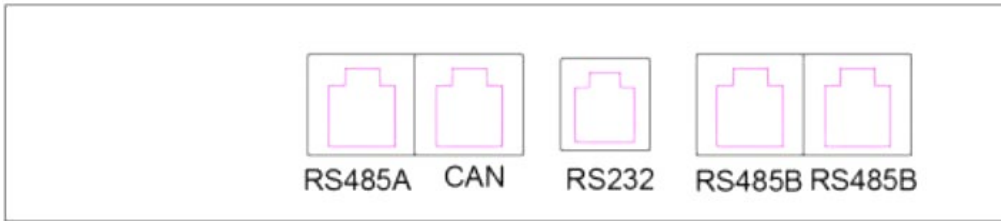

Figure 6.

Step 6: Connect the wiring of the Pack as shown below. see figure 11. If inverter need CAN BUS port /RS485 port. please insert communication cable (RJ45) to CAN port or RS485A,RS485B only be used for battery packs parallel mode.

port 1



RS485A---Communicate with external devices,sample as inverter ,EPS
 CAN ---
 RS232----Communication with host computer
 RS485B---Communication with host computer or parallel communication with battery pack

Figure7

1pack---1 Inverter. Single mode.

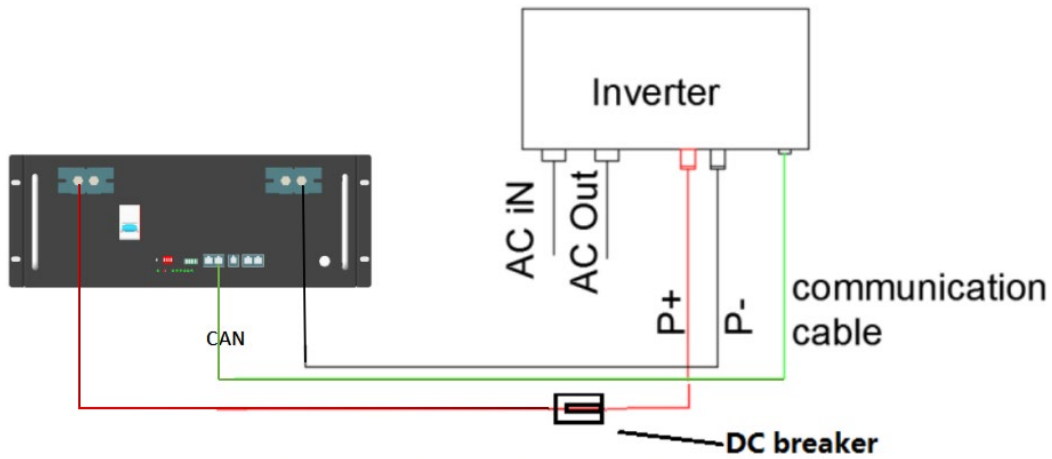

Figure8

2 packs parallel connection with 1 inverter:

1 Pack 1 is slave; pack 2 is master; Negative and Positive power cable has the same length.

Figure9

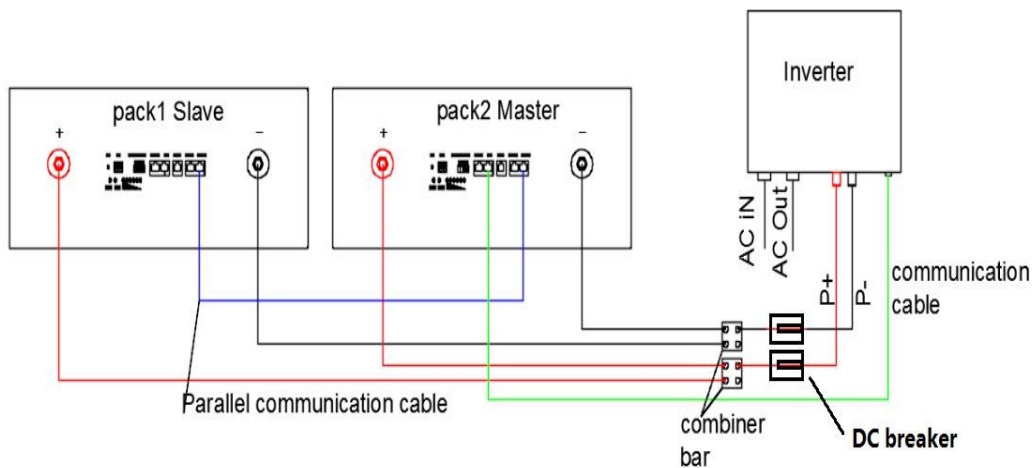

Figure9

3 packs parallel connection with 1 inverter:

Pack 1 ,2 is slave; pack 3 is master. more pack are parallel, one pack is master, other are slave. Negative and Positive power cable has the same. Figure10.

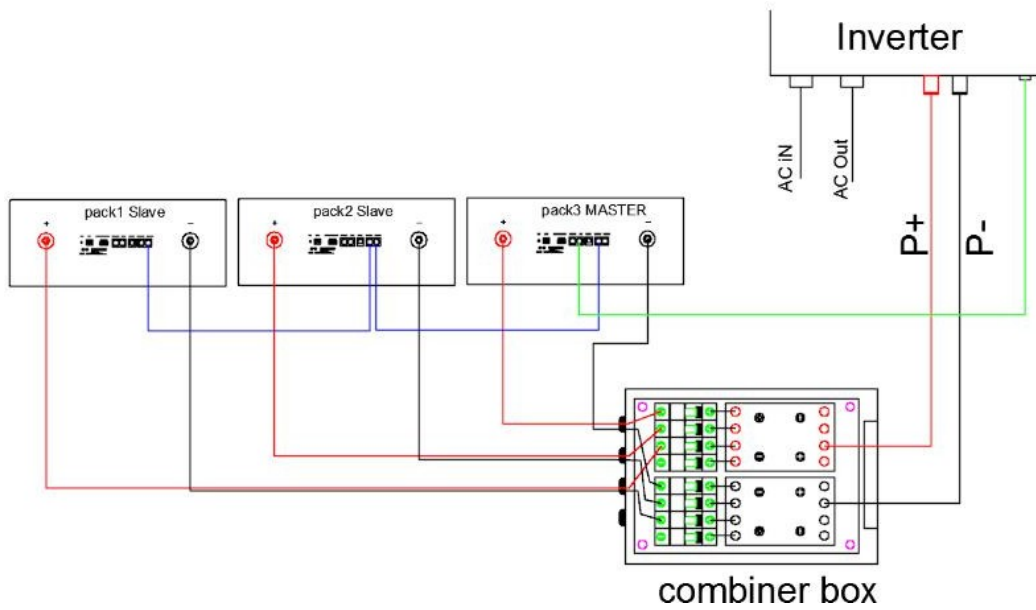
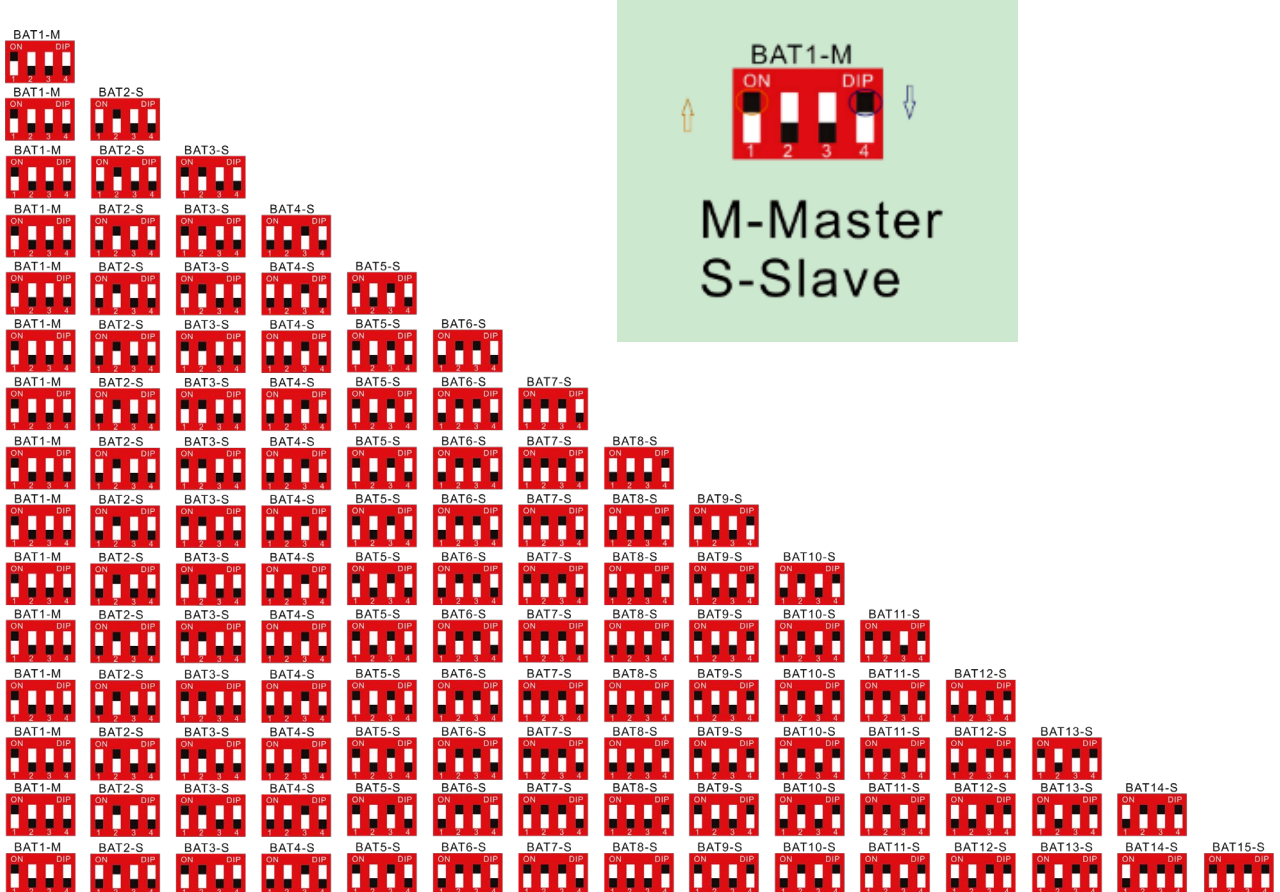

Figure10

Step 7: Set the address of pack. this a important step, you can see there is 4 bit or 8bit coder in bottom of pack. please set as bill 1 and 2.

2 bit CODER: this is Binary CODER, Calculated by 8 4 2 1 BCD code. PACK 1 set as Master (BCD 1 0 0 0),see bill1.It support 15 PCS pack(max) in parallel. Address "0" is only used for single mode.



this is 4bits coder and communication port. CAN port and RS485A port can be selected as the same time.



| | | | | | |
|----------------------------------|--|-------------|----------|---------------|---------|
| Parallel communication | | RS485B-8P8C | | RS485B-8P8C | |
| | | RJ45 | | RJ45 | |
| | | 1,8 | RS485-B | 9,16 | RS485-B |
| | | 2,7 | RS485-A | 10,15 | RS485-A |
| | | 3,6 | GND | 11,14 | GND |
| External communication | | RS485A port | | CAN port | |
| | | RJ45 | | RJ45 | |
| | | 1,8 | RS485-B1 | 9,10,11,14,16 | |
| | | 2,7 | RS485-A1 | 12 | CAN-L |
| | | 3,6 | GND | 13 | CAN-H |
| Communication with host computer | | RS232 | | | |
| | | RJ11 | | RJ11 | |
| | | 1 | NC | 4 | RX |
| | | 2 | NC | 5 | GND |
| | | 3 | TX | 6 | NC |

NOTE: The output connected to the communication cable with a waterproof plug is listed according to the order requirements, which are customized products, and are not listed here.

Step 8: Connect the parallel communication cable (yellow network line). Any Pack has 2 PCS RS485B port for parallel communication, 1 PCS RS485A and 1PCS CAN port for inverter or other device. RS232 port only used for host software and update the firmware.

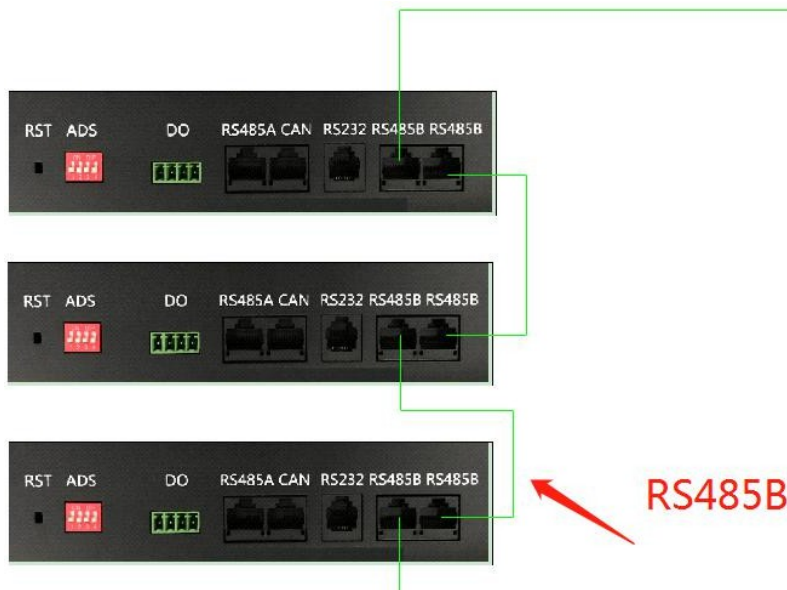
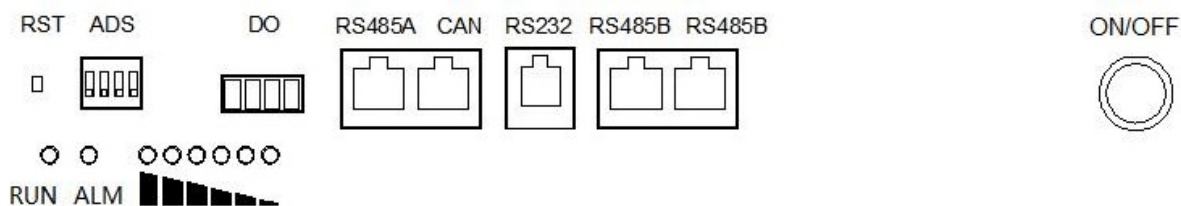

Figure10

Step 9: Start and stop battery pack. Confirm that the operation is correct, and the battery function can

be turned on after the wiring is correct, and You can press down power switch (ON/OFF) 3 second for start battery pack, then turn on switch in the combiner box , the battery start working and output ,it enter standby mode(if there is no power switch, please use a little pole and press down the RESET key 3-6second,like as follow picture, LED indicate all running status and check itself).



Note1: You need to turn on the low side switch first (Discharge negative); then turn on high side (Discharge positive), if any of pack has mistaken or alarm, you'd turn off the switch which connect to this pack, check and reset the pack, then turn on switch again. Turn off the pack, you must turn off the high side switch, then turn off low side switch.

Note2: When the external device needs a large current to start, it is necessary to turn on the power switches (not E-switch) of at least two batteries at the same time.

Step 10: Running the device, set the external charger or inverter parameters, please set according to the corresponding operation manual. Cannot exceed the rated parameter requirements.

4.3 Battery Pack parameters:

| No | Item | General Parameter | | |
|----|--|----------------------------|----------------|-----------------|
| 1 | Combination method | 24V | 48V | 51.2V |
| 2 | Rated Capacity (Ah)(typical) | 100/150/200 | 100/150/200 | 100/150/200 |
| 3 | Factory Voltage(V) | 25.6-26.4V | 48-50V | 51-53V |
| 4 | Rate power (Wh) | 2560/3840/5120 | 4800/7200/9600 | 5120/7680/10240 |
| 5 | Charging Voltage(V) recommend/max | 28/28.8V | 54/54.6V | 57/57.6V |
| 6 | Charging Current(A) recommend/max | 0.2C/0.5C | 0.2C/0.5C | 0.2C/0.5C |
| 7 | Float charge Voltage(V) | 27.6V | 53.5V | 55.5V |
| 8 | Discharge Cut-off Voltage(V) | <=22V | <=41V | <=44V |
| 9 | Max Discharging current(A) | 0.5C | 0.5C | 0.5C |
| 10 | Charging Current limits(A) | / | | |
| 11 | Charge over Current protect(A) | 110/Adjustable | | |
| 12 | Discharge over Current protect(A) | 110/Adjustable | | |
| 13 | Internal Impedance | ≤100mΩ | | |
| 14 | Communication protocol | CAN(500Kb/s)/485A(9600B/S) | | |
| 15 | Host software and Communication protocol | RS232/485B | | |
| 16 | Operation Temperature Range | Charge:0~55°C | | |
| | | Discharge: -20~55°C | | |
| 17 | Storage Temperature Range(recommend) | 0°C~25°C | | |

Step 11: Monitor all running status, and record all parameters, if there has any mistake, please

record it. After start the system, every pack is on, and led indicate this status.

Step 12: Stop running battery pack.

When it is necessary to stop the charging and discharging of the battery or troubleshooting, please stop the external equipment first, cut off the input and output circuits, and then press the power switch off each battery pack.

Appendix 1

SOC Indicator & Status Indicator Guides

Chart 1: Pack led indicate.

| RUN | ALM | Capacity LED | | | | | | | Description | |
|-----|-----|--------------|---|---|---|---|---|---|-------------|--|
| ● | ● | ● | ● | ● | ● | ● | ● | ● | ● | |

Chart 2: Pack Capacity indicate(电池电量指示)

| Status | Normal/ Warning/ Protection | RUN | ALM | Capacity LED | | | | | | Description | |
|-----------|-----------------------------------|-------|-------|-------------------|-----|-----|-----|-----|-----|-------------|------------------------------|
| | | ● | ● | ● | ● | ● | ● | ● | ● | | ● |
| Shut Down | Shut down | OFF | OFF | OFF | OFF | OFF | OFF | OFF | OFF | OFF | All OFF |
| Standby | Normal | Flash | OFF | OFF | OFF | OFF | OFF | OFF | OFF | OFF | Standby |
| Charge | Normal | ON | OFF | Based on capacity | | | | | | | |
| | Warning | ON | Flash | | | | | | | | |
| | Protection | ON | ON | | | | | | | | |
| Discharge | Normal | ON | OFF | Based on capacity | | | | | | | |
| | Warning | ON | Flash | | | | | | | | |
| | Protection | OFF | ON | OFF | OFF | OFF | OFF | OFF | OFF | OFF | UVP,OCP... |
| Fault | Protection | OFF | ON | OFF | OFF | OFF | OFF | OFF | OFF | OFF | Stop charging or discharging |

Appendix 2

A host soft operation:

When the equipment manufacturer confirms that it is necessary, it can authorize to provide the customer with the host software and operating instructions.

| 名称 | 修改日期 | 类型 | 大小 |
|-----------------------------|------------------|-----------|--------|
| Config | 2022/2/25 11:23 | 文件夹 | |
| PbmsTools V2.5FN | 2020/3/2 15:59 | 应用程序 | 669 KB |
| PbmsTools V2.5FN.exe.config | 2021/12/17 16:31 | CONFIG 文件 | 1 KB |

B Host soft operation:

The screenshot displays the PbmsTools V2.5FN software interface. The main window is titled 'PbmsTools V2.5FN' and features a green header bar. Below the header, there are several tabs: 'Realtime Monitoring', 'Multi Monitoring', 'Memory Info.', 'Parameter Setting', 'System Config.', and 'Export Datas'. The 'Realtime Monitoring' tab is active, showing a grid of 15 cells (1-15) at the top.

Pack Information:

- Pack Voltage: 51.363 V
- Pack Current: 0.00 A
- SOC: 48 %
- SOH: 100 %
- RemainCapacity: 96810 mAh
- FullCapacity: 200000 mAh
- Battery Cycle: 0

Temperature:

- Tcell 1: 19.9 °C
- Tcell 2: 19.8 °C
- Tcell 3: 19.7 °C
- Tcell 4: 19.8 °C
- MOS_T: 21.7 °C
- ENV_T: 22.6 °C

Cell Voltage(mV):

- MaxVolt: 10 (3206)
- MinVolt: 1 (3204)
- VoltDiff: 2
- Vcell 1-16: 3204, 3205, 3205, 3205, 3205, 3205, 3205, 3205, 3204, 3205, 3205, 3205, 3204, 3205, 3205, 3205

Serial Port:

- Port: COM8
- Baud Rate: 9600
- Auto Display:
- Pack: 1
- Pack Qty: 1
- ADDR: 1
- Interval (S): 1
- Buttons: Close, Try Connect

System Status:

- CHARGING-ON (selected)
- DISCHARGING-ON (selected)
- Other options: CHARGING, CHG-LIMIT-OFF, ACin, DISCHARGING, HEATER-OFF, Fully

Alarm Status: None

Protect Status: None

Fault Status: None

Switch Control:

- CHG Circuit: Close
- Sound Alarm: Open
- CHG Limiter: Close
- DSG Circuit: Close
- LED Alarm: Close
- Shutdown: Off

Password: [Masked] Change Clear

Footer:

- VER: P16S100A-14555-2.01
- BMS S/N: 9865201410053X
- PACK S/N: A635-2202-00028
- COMM: Normal
- 10:13:33 2022/02/28

Appendix 3 Trouble shoot

1 battery pack stop work.

A: turn on switch, be sure it is ON; if battery is low SOC.it need to charging in.

B: Battery pack low volt or enter sleep mode, there you will press down "RST" button 3-6 second, or charging in.



2 No communication, inverter cannot receive any DATA from BMS.

A : Check whether if communication cable is OK, check RJ45 PIN

P1:RS485A-B

P2:RS485V-A

P4:CAN-H

P5:CAN-L



P1:RS485B-A

P1:RS485B-B

B: Replace the communication line. Please give feedback to the dealer and exchange it.

C: Check inverter or other device which connect to BMS, update it is firmware.

D:If the communication function needs to be upgraded, please consult the agent or manufacturer.

E: confirm your inverter and battery protocol is correct, Different protocol or different connection will make a mistake.

3 Battery pack report SOC is mistake.

A: Inverter received Data from Master BMS, but it is SOC <total SOC, sample as :9PCS packs has 1800Ah, but inverter read DATA is 1600Ah. So you may check any one is disconnected. Check RS485B communication cable(yellow),RS485 communication cable ,replace the cable which is broken.RJ45 PIN:

RS485A:PIN2:485-A,PIN1:485-B;

B: SOC DATA has Large tolerance.

Discharge empty the battery first, then charge it fully with a small current, and learn to discharge. Any pack is mistake ,we advice you read the BMS Data(When we authorize the terminal to use) with host software. then we reset the BMS and calibration .

C: When multiple batteries are connected in parallel, the SOC is different.

We recommend that each pack has a small current discharged and it is emptied until the SOC alarm appears, and then recharged in parallel and fully charged.

4 How to turn on the Pack to discharge . we recommend method is :

A: reset the single pack's BMS,LED will flash and start work

B:turn on the power switch on the bottom/front panel;

C:turn on power switch in the combiner box .

5 When batteries are discharged in parallel and start fail .Alarm LED light and flash.

A: When the startup current of the external device exceeds the total current provided by the battery pack, it will cause over current protection. At this time, it is necessary to turn off the switch of the combiner box, and then turn off the power switch of the every pack;

B: Reset every pack once(there you will press down "RST" button 3-6 second,).We recommended to turn on two power switches synchronously at a time when starting again, and finally restart the switch of the combiner box. If there is no combiner box system, the charging function can be turned on with an external device, and this protection state can be released by charging with a small current.

C: if the packs connect to inverter, you'd turn on pack's power switch first, and then start the inverter .

WARNING:

The operating parameters of the equipment cannot exceed the rated working voltage and current of the Pack exceed the rated volt and current, Can cause damage to the Pack or other failures.

6 Inverter or other external device cannot connect the battery. we recommend method is :

A: Check whether the working parameters of the device and battery are appropriate, and improper parameters cannot be matched.

B: When the device is turned on, the current is too large, resulting in battery protection. At this time, you should be able to see the LED flashing from the battery panel.in this case, You can adjust your equipment parameters or contact the dealer to solve.

C:it is necessary to update BMS parameters and match the device, then Reset BMS and restart your device.

7 Replace bad Pack .

There is a bad battery pack, it is need to replace, please connect your supplier need professional installers to operate it. We recommend replace all or make pack has same voltage and same specification batteries

pack.

NOTE: When replacing the battery, the same module needs to be replaced at the same time, and the voltage should be the same .

8 Need to replace spare parts or emergency maintenance .

Some parts can be obtained from the sales or agency, and the excess parts need to be purchased separately. Be careful, turn off the power switch before replacing parts.

9 Need to place some safety device for keep a safe environment.

You'd keep a safe case for Pack and external device, please place safety device, as: fire-fighting sand, fire- fighting blankets, fire-fighting water pipes, Install Monitor sound, light, electricity, smoke and other equipment.

WARNING:

Emergency process:

1 . The external device catches fire and explodes:

A: Under the condition of ensuring safety, non-operating personnel immediately move to a safe location;

B: Under the condition of ensuring safety, the operator immediately cut off the external power supply of the equipment and the internal power supply.

C: Use fire-fighting equipment for fire-fighting treatment (the use of fire-fighting sand, fire-fighting blankets, fire- fighting water pipes)

D: If you cannot completely extinguish the fire, please call the local fire department for help.

E: Keep the accident site data so that the source of the accident can be traced.

2 . The Pack catches fire and explodes:

A: Under the condition of ensuring safety, non-operating personnel immediately move to a safe location;

B: Under the condition of ensuring safety, the operator immediately cut off the external power supply of the equipment and the internal power supply.

C: Use fire-fighting equipment for fire-fighting treatment (first the use of fire-fighting sand, fire-fighting blankets, then fire-fighting water pipes for cool the Pack)

D: If you cannot completely extinguish the fire, please call the local fire department for help.

E: Keep the accident site data so that the source of the accident can be traced.

Product Responsibilities and Consulting

We will not be liable for the accidents resulting from operation breaking this specification and user manual.

- We will not send separate notice, provided that the contents of this specification are changed due to improvement of product quality or technological upgrading; provided that you want to understand the latest information of this product, please contact us.
- The shelf life of this product is within 36 months after it is delivered; we will maintain the product, which is in the warranty period for free of charge, provided that it has any product.
- quality problems within the specified operation range; we may replace the relevant parts, if we fail to maintain it, so as to achieve the purpose of sustainable use without performance reduction; our after-sales service personnel will propose the specific maintenance and troubleshooting methods. In case of any questions, please contact us.

Warranty Term & Card

1. Product Warranty

- 1.1. If you have purchased this product from factory, you should be aware that this warranty is provided in addition to other rights and remedies held by a consumer at law.
- 1.2. You are entitled to a replacement or refund for a major failure and for compensation for any other reasonably foreseeable loss or damage. You are also entitled to have the goods repaired or replaced if the goods fail to be of acceptable quality and the failure does not amount to a major failure.
- 1.3. For the above-mentioned products, you receive the factory warranty valid for 5-10 years from the date of delivery from factory. The factory warranty covers any costs for repair or spare parts during the agreed period beginning on the date of delivery of the device, subject to the following conditions.

1.4. Factory Warranty Scope

The factory warranty does not cover damages caused by following reasons:

- **Breaking the product seal (opening the casing)**
- **Transport damage**
- **Incorrect installation or commissioning**
- **Failure to observe the user manual, quick installation instructions**
- **Incorrect usage or inappropriate operation**
- **Insufficient ventilation of the device**
- **Failure to observe the applicable safety regulations**
- **Force majeure**

Neither does it cover cosmetic defects which do not influence the energy production.

1.5. Warranty conditions

If the battery becomes defective during the agreed factory warranty period and, unless this should be impossible or disproportionate, one of the following options will be selected at the discretion of factory:

- **Battery repair or**
- **Battery repair at on-site, or**
- **Exchange for a replacement device of equivalent value with regard to model and age.**

In the latter case, the remainder of the warranty entitlement will be transferred to the replacement device and your entitlement will be documented at factory.

Excessiveness in the meaning above exists in particular if the cost the measures for factor will be unreasonable.

- In view of the value that the device would have without the defect
- Taking in account of the significance of the defect, and
- After consideration of alternative work around possibilities at factory customers could revert to without significant inconvenience.

Thank you very much to choose YouthPower Solar Storage Batteries. Please fill the required information in and send this page to factory when you need to apply warranty service support

Warranty Card

User Information

Company / User Name:

Address:

Telephone:

Email:

Project installation location:

Product Information

Battery Model:

Serial No.:

(**Close to the battery BMS**) – **Important for service**

Invoice Number :

Purchase Date :

Dealer :

Commission date :

Fault/Error:

Description: