

# **LS-B、VS-B、Tracer-B、Tracer-A、iTracer-B、e Tracer-B Series Controller Communication Instruction**

Modbus is an application layer packet transmission protocol and it lies in 7 layer of OSI model. It provides client / server communication between the different network equipment. Modbus is also a request / response protocol, and provides the services of function code.

As a master / slave protocol, at the same time, there is only one master and one or more(at most 247) slave on the bus. Modbus communication is always initiated by the master, and if no request is received from the master to the slave, no data will be sent. The slaves can not communicate with each other, at the same time the master can only initiate one Modbus transaction.

Our product communication protocol has the following characteristics :

1. Communication protocol is standard Modbus-RTU protocol.
2. The default controller ID number is "1", we can modify the ID via PC common software or MT50 LCD unit (Tips: when modify ID, please make sure the bus only connects a controller. After modifying the ID,please recharge the controller.)
3. Serial communication parameters: baud rate 115200, data bits 8, stop bits 1, no data flow control.
4. Register address uses hexadecimal format, The base address offset is 0x00.

5. All 32-bit-length data uses two 16-bit registers to represent(L and H register,respectively), for example, the value of the array rated power is 3000, data multiple is 100, the data of L register (address 0x3002)is 0x93E0 and the data of H register(address 0x3003) is 0x0004.

**Real Time Data: all system's real time data , real time status and the history statistics of energy generated and energy consumed.**

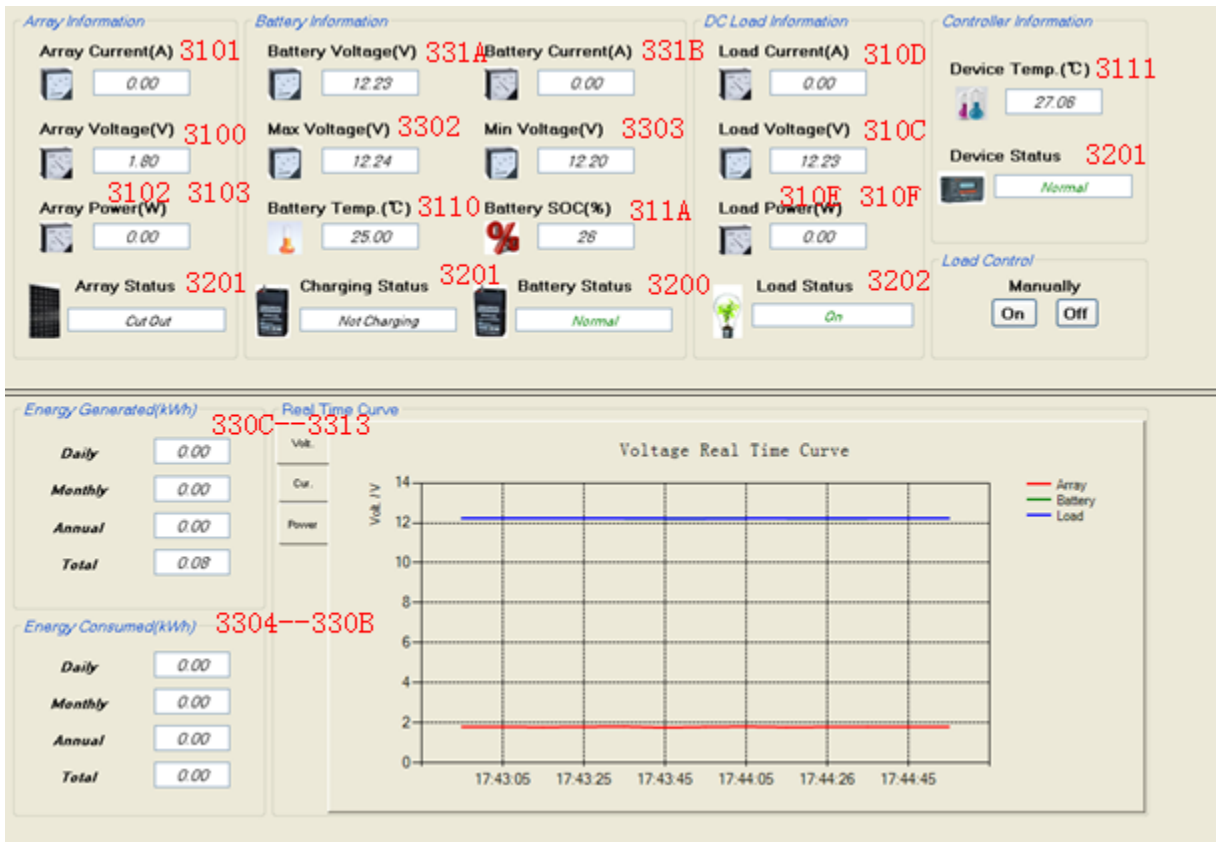

Number	Variable name	Address	Function code	Description	Unit	Times
A1	Over temperature inside the device	2000	02 (read)	1 The temperature inside the controller is higher than the over-temperature protection point. 0 Normal		
A2	Day/Night	200C	02 (read)	1-Night, 0-Day		
A3	PV array input voltage	3100	04 (read)	Solar charge controller--PV array voltage	V	100
A4	PV array input current	3101	04 (read)	Solar charge controller--PV array current	A	100
A5	PV array input power L	3102	04 (read)	Solar charge controller--PV array power	W	100
A6	PV array input power H	3103	04 (read)	Solar charge controller--PV array power	W	100
A7	Load voltage	310C	04 (read)	Load voltage	V	100

A8	Load current	310D	04 (read)	Load current	A	100
A9	Load power L	310E	04 (read)	Load power	W	100
A10	Load power H	310F	04 (read)	Load power	W	100
A11	Battery temperature	3110	04 (read)	Battery temperature	°C	100
A12	Device temperature	3111	04 (read)	Device temperature	°C	100
A13	Battery SOC	311A	04 (read)	The percentage of battery's remaining capacity	%	1
A14	Battery's real rated voltage	311D	04 (read)	Current system rated voltage. 1200, 2400, 3600, 4800 represent 12V, 24V, 36V, 48V	V	100
A15	Battery status	3200	04 (read)	D15: 1-Wrong identification for rated voltage D8: Battery inner resistance abnormal 1, normal 0 D7-D4: 00H Normal, 01H Over Temp.(Higher than the warning settings), 02H Low Temp.(Lower than the warning settings), D3-D0: 00H Normal ,01H Over Voltage. , 02H Under Voltage, 03H Over discharge, 04H Fault		
A16	Charging equipment status	3201	04 (read)	D15-D14: Input voltage status. 00H normal, 01H No input power connected, 02H Higher input voltage , 03H Input voltage error. D13: Charging MOSFET is short circuit. D12: Charging or Anti-reverse MOSFET is open circuit. D11: Anti-reverse MOSFET is short circuit. D10: Input is over current. D9: The load is over current. D8: The load is short circuit. D7: Load MOSFET is short circuit. D4: PV input is short circuit. D3-D2: Charging status. 00H No charging,01H Float,02H Boost, 03H Equalization.		

				D1: 0 Normal, 1 Fault. D0: 1 Running, 0 Standby.		
A17	Discharging equipment status	3202	04 (read)	D15-D14: 00H Input voltage normal, 01H Input voltage low, 02H Input voltage high, 03H no access. D13-D12: Output power. 00H Light load, 01H Moderate, 02H rated, 03H overload D11: Short circuit D10: Unable to discharge D9: Unable to stop discharging D8: Output voltage abnormal D7: Input over voltage D6: Short circuit in high voltage side D5: Boost over voltage D4: Output over voltage D1: 0 Normal, 1 Fault. D0: 1 Running, 0 Standby.		
A18	Maximum battery voltage today	3302	04 (read)	00: 00 Refresh every day	V	100
A19	Minimum battery voltage today	3303	04 (read)	00: 00 Refresh every day	V	100
A20	Consumed energy today L	3304	04 (read)	00: 00 Clear every day	KWH	100
A21	Consumed energy today H	3305	04 (read)		KWH	100
A22	Consumed energy this month L	3306	04 (read)	00: 00 Clear on the first day of month	KWH	100
A23	Consumed energy this month H	3307	04 (read)		KWH	100
A24	Consumed energy this year L	3308	04 (read)	00: 00 Clear on 1, Jan	KWH	100
A25	Consumed energy this year H	3309	04 (read)		KWH	100
A26	Total consumed energy L	330A	04 (read)		KWH	100
A27	Total consumed energy H	330B	04 (read)		KWH	100
A28	Generated energy today L	330C	04 (read)	00: 00 Clear every day.	KWH	100
A29	Generated energy today H	330D	04 (read)		KWH	100
A30	Generated energy this month L	330E	04 (read)	00: 00 Clear on the first day of month.	KWH	100

A31	Generated energy this month H	330F	04 (read)		KWH	100
A32	Generated energy this year L	3310	04 (read)	00: 00 Clear on 1, Jan.	KWH	100
A33	Generated energy this year H	3311	04 (read)		KWH	100
A34	Total generated energy L	3312	04 (read)		KWH	100
A35	Total generated energy H	3313	04 (read)		KWH	100
A36	Battery voltage	331A	04 (read)	Battery voltage	V	100
A37	Battery current L	331B	04 (read)	Battery current	A	100
A38	Battery current H	331C	04 (read)	Battery current	A	100

## Status analysis

Array status: address 3201 bits D15-D10

Charging status: address 3201 bits D3-D2

Battery status: address 3200 bits D7-D0

Load status: address 3201 bits D9-D7,D5 address 3202 bits D13-D8,D6-D4

Device status: address 3200 bit D15 address 3201 bits D6-D5 address 2000

## For example

### Read real-time battery voltage

Send command: 01 04 33 1A 00 01 1F 49

Analysis :

01 device ID  
04 function code  
33 1A the start bit of the address  
00 01 the number of the address  
1F 49 CRC

Receive command : 01 04 02 04 CE 3A 64

Analysis :

01 device ID  
04 function code  
02 two bytes  
04 CE data (0x04CE (Hex) = 1230 (Dec), 1230/100=12.3V)  
3A 64 CRC

**Battery Parameter:** After choosing the battery type , set the corresponding parameter, and mainly set the reasonable parameter to the special voltage.

Station Name  Device ID

Rated Voltage (V)  Rated Load Current (A)  Rated Charging Current (A)

	Default	Current		Default	Current
9000 Battery Type	Sealed	User	9067 Rated Voltage Level	12V	12V
9070 Charging Mode	Volt. Comp.	Volt. Com	906C Boost Duration (m)	120	120
9001 Battery Capacity (Ah)	200	200	906B Equilibrium Duration (m)	120	120
9002 Temp. Compensation Coefficient (mV/°C/2V)	-3	-2	9004 Charging Limit Voltage (V)	15.00	14.60
9003 Over Volt. Disconnect Volt. (V)	16.00	15.40	900E Discharging Limit Volt. (V)	10.60	9.50
9005 Over Volt. Reconnect Volt. (V)	15.00	14.60	900D Low Volt. Disconnect Volt. (V)	11.10	10.10
9006 Equilibrium Charging Volt. (V)	14.60	14.60	900A Low Volt. Reconnect Volt. (V)	12.60	11.10
9007 Boost Charging Volt. (V)	14.40	14.60	900C Under Vol. Warning Volt. (V)	12.00	11.00
9008 Float Charging Volt. (V)	13.80	14.50	900B Under Volt. Warn. Reco. Volt. (V)	12.20	11.20
9009 Boost Recon. Charg. Volt. (V)	13.20	13.50	906D Battery Discharge (%)	30	80
906E Battery Charge (%)	100	100			

Read Update Restore Default Export Settings Import Settings

Number	Variable name	Address	Function code	Description	Unit	Times
B1	Rated charging current	3005	04(read)	Rated current to battery	A	100
B2	Rated load current	300E	04(read)	Rated current to load	A	100
B3	Battery's real rated voltage	311D	04(read)	Current system rated voltage. 1200, 2400, 3600, 4800 represent 12V, 24V, 36V, 48V	V	100
B4	Battery type	9000	03 (read) 10 (write)	0000H User defined, 0001H Sealed , 0002H GEL, 0003H Flooded,		
B5	Battery capacity	9001	03 (read) 10 (write)	Rated capacity of the battery	AH	
B6	Temperature compensation coefficient	9002	03 (read) 10 (write)	Range 0-9	mV/ °C /2V	100
B7	Over voltage disconnect	9003	03 (read) 10 (write)		V	100

	voltage					
B8	Charging limit voltage	9004	03 (read) 10 (write)		V	100
B9	Over voltage reconnect voltage	9005	03 (read) 10 (write)		V	100
B10	Equalize charging voltage	9006	03 (read) 10 (write)		V	100
B11	Boost charging voltage	9007	03 (read) 10 (write)		V	100
B12	Float charging voltage	9008	03 (read) 10 (write)		V	100
B13	Boost reconnect charging voltage	9009	03 (read) 10 (write)		V	100
B14	Low voltage reconnect voltage	900A	03 (read) 10 (write)		V	100
B15	Under voltage warning recover voltage	900B	03 (read) 10 (write)		V	100
B16	Under voltage warning voltage	900C	03 (read) 10 (write)		V	100
B17	Low voltage disconnect voltage	900D	03 (read) 10 (write)		V	100
B18	Discharging limit voltage	900E	03 (read) 10 (write)		V	100
B19	Battery rated voltage level	9067	03 (read) 10 (write)	0, auto recognize. 1-12V, 2-24V, 3-36V, 4-48V, 5-60V, 6-110V, 7-120V, 8-220V, 9-240V		
B20	Default load On/Off in manual mode	906A	03 (read) 10 (write)	0-off, 1-on		
B21	Equalize duration	906B	03 (read) 10 (write)	Usually 60-120 minutes	Min	
B22	Boost duration	906C	03 (read) 10 (write)	Usually 60-120 minutes	Min	
B23	Battery	906D	03 (read)	Usually 20%-80%. The percentage of	%	100



	discharge		10 (write)	battery's remaining capacity when stop charging		
B24	Battery charge	906E	03 (read) 10 (write)	Depth of charge, 100%	%	100
B25	Charging mode	9070	03 (read) 10 (write)	Management modes of battery charge and discharge, voltage compensation : 0 and SOC : 1		

## Voltage parameters limit condition

- 1 Over voltage disconnect voltage>Charge limit voltage>Equalize charging voltage>Boost charging voltage>Float charging voltage>Boost reconnect charging voltage
- 2 Under voltage warning recover voltage>Under voltage warning voltage>Low voltage disconnect voltage>Discharging limit voltage
- 3 Over voltage disconnect voltage>Over voltage reconnect voltage
- 4 Low voltage reconnect voltage>Low voltage disconnect voltage

## Warning

- 1 When the battery type is Sealed、Gel or Flooded, the customer only can set Charging mode、battery capacity、temperature compensation coefficient、equalize duration、boost duration (you can not set the Equalize duration when the battery type is Gel) . Only when the battery type is User, the customer can set the other parameters(the parameters need to be set at the same time)
- 2 Battery discharge and battery charge can be set when the charging mode is SOC
- 3 The battery type and battery rated voltage level can not be User and Self-recognition at the same time

## For example:

Read battery parameter (battery type: user rated voltage level: 12V)

Send command: 01 03 90 00 00 0F 28 CE

Analysis :

```

01          device ID
03          function code
90 00       the start bit of the address
00 0F       the number of the address
28 CE      CRC

```

Receive command: 01 03 1E 00 00 00 C8 01 2C 06 40 05 DC 05 DC 05 B4 05 A0 05 64 05 28 04 EC  
04 C4 04 B0 04 56 04 24 72 A5

Analysis: :

```

01          device ID
03          function code

```

1E the number of the sending data  
00 00 00 C8 01 2C 06 40 05 DC 05 DC 05 B4 05 A0 05 64 05 28 04 EC 04 C4 04 B0 04 56  
04 24 the sending data (00 00 battery type(User) 00 C8  
battery capacity(200) 01 2C temperature compensation  
coefficient(3) 06 40 Over voltage disconnect  
voltage(16V) 05 DC Charge limit voltage(15V)  
05 DC Over voltage reconnect voltage(15V) 05 B4  
Equalize charging voltage(14.6V) 05 A0 Boost  
charging voltage(14.4V) 05 64 Float charging  
voltage(13.8V) 05 28 Boost reconnect charging  
voltage(13.2V ) 04 EC Low voltage reconnect  
voltage(12.6V) 04 C4 Under voltage warning recover  
voltage(12.2V) 04 B0 Under voltage warning  
voltage(12V) 04 56 Low voltage disconnect  
voltage(11.1V) 04 24 Discharging limit voltage(10.6V)  
3C C4 CRC

Send command : 01 03 90 67 00 01 18 D5

Analysis :

01 device ID  
03 function code  
90 67 the start bit of the address  
00 01 the number of the address  
18 D5 CRC

Receive command : 01 03 02 00 01 79 84

Analysis :

01 device ID  
03 function code  
02 the number of the sending data  
00 01 the sending data (12V system)  
79 84 CRC

Send command : 01 03 90 6B 00 02 98 D7

Analysis :

01 device ID  
03 function code  
90 6B the start bit of the address  
00 02 the number of the address  
98 D7 CRC

Receive command : 01 03 04 00 78 00 78 7A 08

Analysis:

01 device ID  
03 function code  
04 the number of the sending data  
00 78 00 78 the sending data (00 78 equalize duration(120Min) 00 78  
boost duration (120Min)  
7A 08 CRC

**Load parameter: set the load control mode to meet the customer's demand**

Station Name  Device ID

Load Control Mode **903D**

**0000H** Manually On By Default
  **0001H** Manually Off By Default

**0001H** Timing Control
 Turn-On Time1  **9042--9044** Turn-Off Time1  **9045--9047**  
 **9069** Turn-On Time2  **9048--904A** Turn-Off Time2  **904B--904D**

**0003H** Light On
 Turn-On Volt. (V)  **901E** Delay (m)  **901F**  
 Turn-Off Volt. (V)  **9020** Delay (m)  **9021**

**0002H** Light On + Time
 Work Time1  **903E** Work Time2  **903F**  
 Night Time (h)  :  **9065**

Number	Variable name	Address	Function code	Description	Unit	Times
C1	Manual control the load	2	05 (write)	When the load is manual mode, 1-manual on 0 -manual off		
C2	Night time threshold voltage(NTTV)	901E	03 (read) 10 (write)	PV voltage is lower than this value, controller would detect it as sundown	V	100
C3	Light signal startup (night) delay time	901F	03 (read) 10 (write)	PV voltage is lower than NTTV, and duration exceeds the Light signal startup (night) delay time, controller would detect it as night time.	Min	
C4	Day time threshold voltage(DTTV)	9020	03 (read) 10 (write)	PV voltage is higher than this value, controller would detect it as sunrise	V	100
C5	Light signal close (day) delay time	9021	03 (read) 10 (write)	PV voltage higher than DTTV, and duration exceeds the Light signal close (day) delay time, controller would detect it as day time.	Min	
C6	Load control mode	903D	03 (read) 10 (write)	0000H Manual Control 0001H Light ON/OFF 0002H Light ON+ Timer/ 0003H Timing Control		
C7	Light on + time(time1)	903E	03 (read) 10 (write)	The length of load output timer1, D15-D8, hour, D7-D0, minute		

C8	Light on + time(time2)	903F	03 (read) 10 (write)	The length of load output timer2, D15-D8, hour, D7-D0, minute		
C9	Timing control (turn on time1)	9042	03 (read) 10 (write)	Turn on/off time of load output.	S	
C10		9043	03 (read) 10 (write)		Min	
C11		9044	03 (read) 10 (write)		H	
C12	Timing control (turn off time1)	9045	03 (read) 10 (write)		S	
C13		9046	03 (read) 10 (write)		Min	
C14		9047	03 (read) 10 (write)		H	
C15	Timing control (turn on time2)	9048	03 (read) 10 (write)		S	
C16		9049	03 (read) 10 (write)		Min	
C17		904A	03 (read) 10 (write)		H	
C18	Timing control (turn off time2)	904B	03 (read) 10 (write)		S	
C19		904C	03 (read) 10 (write)		Min	
C20		904D	03 (read) 10 (write)		H	
C21	Night time	9065	03 (read) 10 (write)	Set default values of the whole night length of time. D15-D8, hour, D7-D0, minute		
C22	Timing control (time choose)	9069	03 (read) 10 (write)	Record the time of load. 0, use one time, 1-use two times, and so on		
C23	Default load On/Off in	906A	03 (read) 10 (write)	0-off, 1-on		

	manual mode					
--	-------------	--	--	--	--	--

## Warning

- 1 First you should choose the load control mode (903D), then set the corresponding parameters.
- 2 Timing control (turn on/off time 2) is based on Timing control (time choose) (9069) .

## For example

Send light on + time

Send command : 01 10 90 3D 00 03 06 00 02 02 00 02 00 F3 9F

Analysis :

01	device ID
10	function code
90 3D	the start bit of the address
00 03	the number of the address
06	six bytes
00 02 02 00 02 00	the sending data (00 02 load control mode(light on + time) 02 00 light on + time(time1)(02 00) 02 00 light on + time(time2)(02 00))
F3 9F	CRC

Receive command : 01 10 90 3D 00 03 3C C4

Analysis :

01	device ID
10	function code
90 3D	the start bit of the address
00 03	the number of the address
3C C4	CRC

Send command : 01 10 90 65 00 01 02 0A 00 39 0C

Analysis :

01	device ID
10	function code
90 65	the start bit of the address
00 01	the number of the address
02	two bytes
0A 00	the sending data (0A hour(10) 00 minute(0))
39 0C	CRC

Receive command : 01 10 90 65 00 01 3C D6

Analysis :

01	device ID
10	function code
90 65	the start bit of the address
00 01	the number of the address
3C D6	CRC

Send command : 01 10 90 1E 00 04 08 01 F4 00 0A 02 58 00 0A B3 6D

Analysis:

01	device ID
10	function code
90 1E	the start bit of the address
00 04	the number of the address
08	eight bytes
01 F4 00 0A 02 58 00 0A	the sending data (01 F4 night time threshold voltage(5V) 00 0A light signal startup (night) delay time(10 minute) 02 58 day time threshold voltage(6V) 00 0A light signal close (day) delay time(10 minute))
B3 6D	CRC

Receive command : 01 10 90 1E 00 04 8C CC

Analysis :

01	device ID
10	function code
90 1E	the start bit of the address
00 04	the number of the address
8C CC	CRC

## Real Time Clock

Station Name  Device ID

Local Time

Device Time  9013--9015

Num ber	Variable name	Addr ess	Function code	Description	Unit	Times
D1	Real time clock	9013	03 (read) 10 (write)	D7-0 Sec, D15-8Min. (Year, Month, Day, Hour,Min, Sec. should be written simultaneously)		
D2	Real time clock	9014	03 (read) 10 (write)	D7-0 Hour, D15-8 Day		
D3	Real time clock	9015	03 (read) 10 (write)	D7-0 Month, D15-8 Year		

For example:

Read the address 0x9013-9015

Send command : 01 03 90 13 00 03 D9 0E

Analysis :

01                    device ID  
 03                    function code  
 90 13                the start bit of the address  
 00 03                the number of the address  
 D9 0E                CRC

Receive command : 01 03 06 1A 1B 18 0B 10 02 BC 2E

Analysis :

01                    device ID  
 03                    function code  
 06                    six bytes  
 1A 1B 18 0B 10 02 the receiving data (1A 26(minute), 1B 27(second), 18 24(day),  
 0B 11(hour), 10 16 (year) , 02 02(month))  
 B7 24                CRC

## Device parameter

Station Name  Device ID

Backlight Control **9063**(0 - 999s)

Device Over Temperature **9019** (40 - 100°C)

Device Recovery Temperature **901A** (30 - 80°C)

Battery Upper Temperature Limit **9017**(50 - 80°C)

Battery Lower Temperature Limit **9018**(0 - -40°C)

Number	Variable name	Address	Function code	Description	Unit	Times
E1	Battery upper temperature limit	9017	03 (read) 10 (write)		°C	100
E2	Battery lower temperature limit	9018	03 (read) 10 (write)		°C	100
E3	Device over temperature	9019	03 (read) 10 (write)		°C	100
E4	Device recovery temperature	901A	03 (read) 10 (write)		°C	100
E5	Backlight time	9063	03 (read) 10 (write)	Close after LCD backlight light setting the number of seconds	S	

### For example

Send the data of 0x9017-0x901A

Send command : 01 10 90 17 00 04 08 19 64 F0 60 21 34 1D 4C 70 10

Analysis :

01                                    device ID  
 10                                    function  
 90 17                                the start bit of the address  
 00 04                                the number of the address  
 08                                    the sending bytes  
 19 64 F0 60 21 34 1D 4C        the sending data  
 70 10                                CRC

Receive data: 01 10 90 17 00 04 5C CE

Analysis :

01                                    device ID  
 10                                    function code  
 90 17                                the start bit of the address  
 00 04                                the number of the address  
 5C CE                                CRC



## Rated parameter

Number	Variable name	Address	Function code	Description	Unit	Times
F1	Array rated voltage	3000	04 (read)	PV array rated voltage	V	100
F2	Array rated current	3001	04 (read)	PV array rated current	A	100
F3	Array rated power L	3002	04 (read)	PV array rated power (low 16 bits)	W	100
F4	Array rated power H	3003	04 (read)	PV array rated power (high 16 bits)	W	100
F5	Battery rated voltage	3004	04 (read)	Rated voltage to battery	V	100
F6	Battery rated current	3005	04 (read)	Rated current to battery	A	100
F7	Battery rated power L	3006	04 (read)	Rated power to battery(low 16 bits)	W	100
F8	Battery rated power H	3007	04 (read)	Rated power to battery(high 16 bits)	W	100
F9	Rated load voltage	300D	04 (read)	Rated voltage to load	V	100
F10	Rated load current	300E	04 (read)	Rated current to load	A	100
F11	Rated load power to L	300F	04 (read)	Rated power to load(low 16 bits)	W	100
F12	Rated load power to H	3010	04 (read)	Rated power to load(high 16 bits)	W	100

For example:

Read the array rated voltage

Send command : 01 04 30 00 00 01 3E CA

Analysis :

01      device ID  
 04      function code  
 30 00   the start bit of the address  
 00 01   the number of the address  
 3E CA   CRC

Receive command : 01 04 02 17 70 B7 24

Analysis :

01      device ID  
 04      function code  
 02      two bytes  
 17 70   the receiving data (0x1770 (Dec), 6000, 6000/100=60V)  
 B7 24   CRC

## The other switching value

Number	Variable name	Address	Function code	Description	Unit	Times
G1	Charging device on/off	0	05 (write)	1 Charging device on 0 Charging device off		
G2	Output control mode manual/automatic	1	05 (write)	1 Output control mode manual 0 Output control mode automatic		
G3	Manual control the load	2	05 (write)	When the load is manual mode, 1-manual on 0 -manual off		
G4	Default control the load	3	05 (write)	When the load is default mode, 1-manual on 0 -manual off		
G5	Enable load test mode	5	05 (write)	1 Enable 0 Disable(normal)		
G6	Force the load on/off	6	05 (write)	1 Turn on 0 Turn off (used for temporary test of the load)		
G7	Restore system defaults	13	05 (write)	1 yes 0 no		
G8	Clear generating electricity statistics	14	05 (write)	1 clear. Root privileges to perform		

For example:

Send restore system defaults command:

Send command : 01 05 00 13 FF 00 7D FF

Analysis :

```

01      device ID
05      function code
00 13   the address of the sending data
FF 00   the sending data (enable restore system defaults)
7D FF   CRC

```

Receive command : 01 05 00 13 FF 00 7D FF

Analysis :

```

01      device ID
05      function code
00 13   the address of the receiving data
FF 00   the receiving data
7D FF   CRC

```

## Pin Definition

1. The RJ45 interface pin define for RS485 port of LS-B、VS-B、Tracer-B 、Tracer-A series controllers is shown below:

Pins define:

Pins	Define
1	Power supply output +5V
2	Power supply output +5V
3	RS-485-B
4	RS-485-B
5	RS-485-A
6	RS-485-A
7	Ground
8	Ground

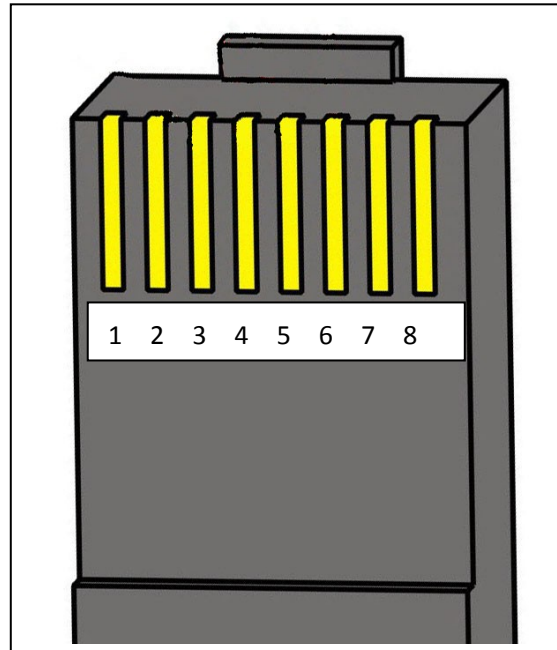

RJ45 plug pins are sorted by number, the sketch map is as shown above:

2. The interface pin definition for RS485 and RS232 port of iTracer-B、eTracer-B series controllers is shown below:

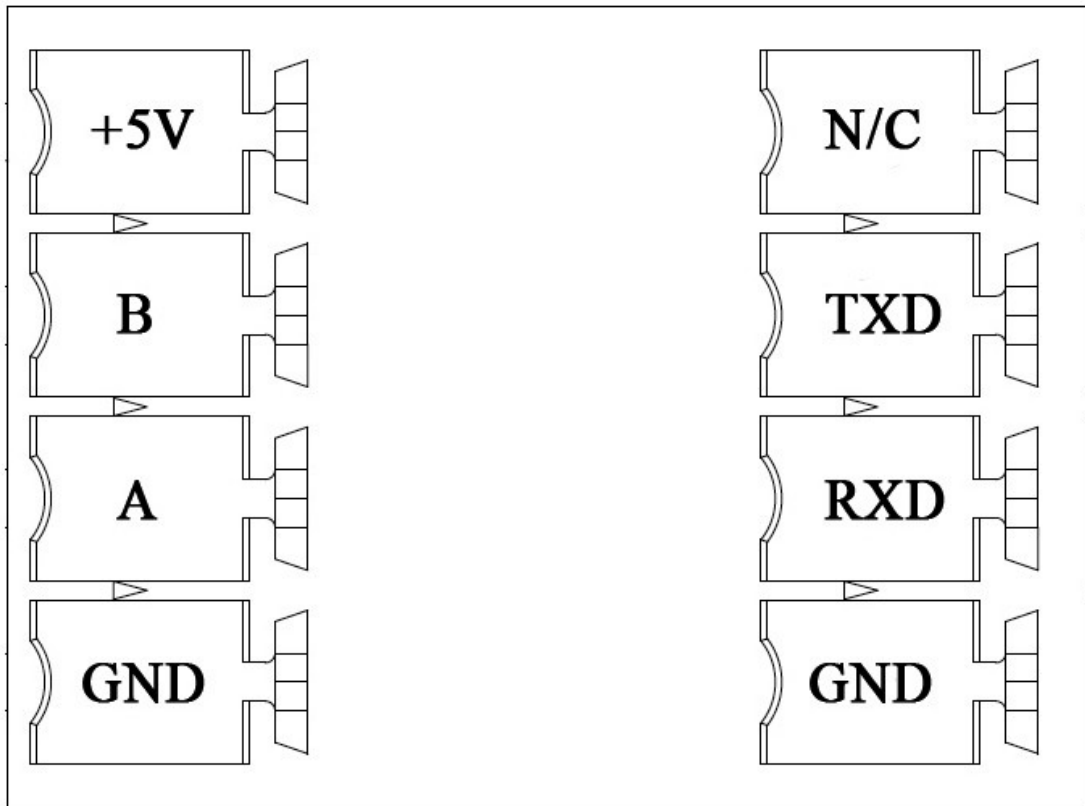

Note:

(1)To improve the communication quality, the Gound pins(connected with the negative terminal of the battery) could be used if necessary. However, the user must care the common ground problem of the connected devices.

(2)Do not use the Vcc pins (+5v), or the controller may be damaged permanently.